

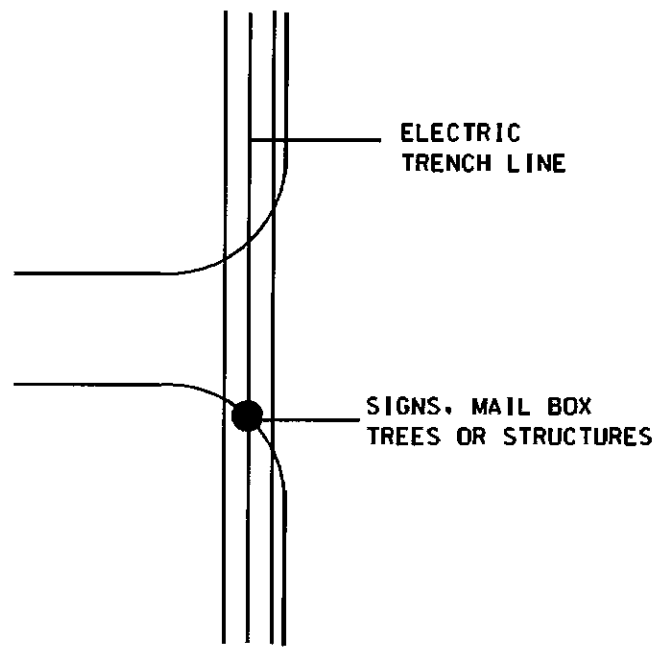

YES

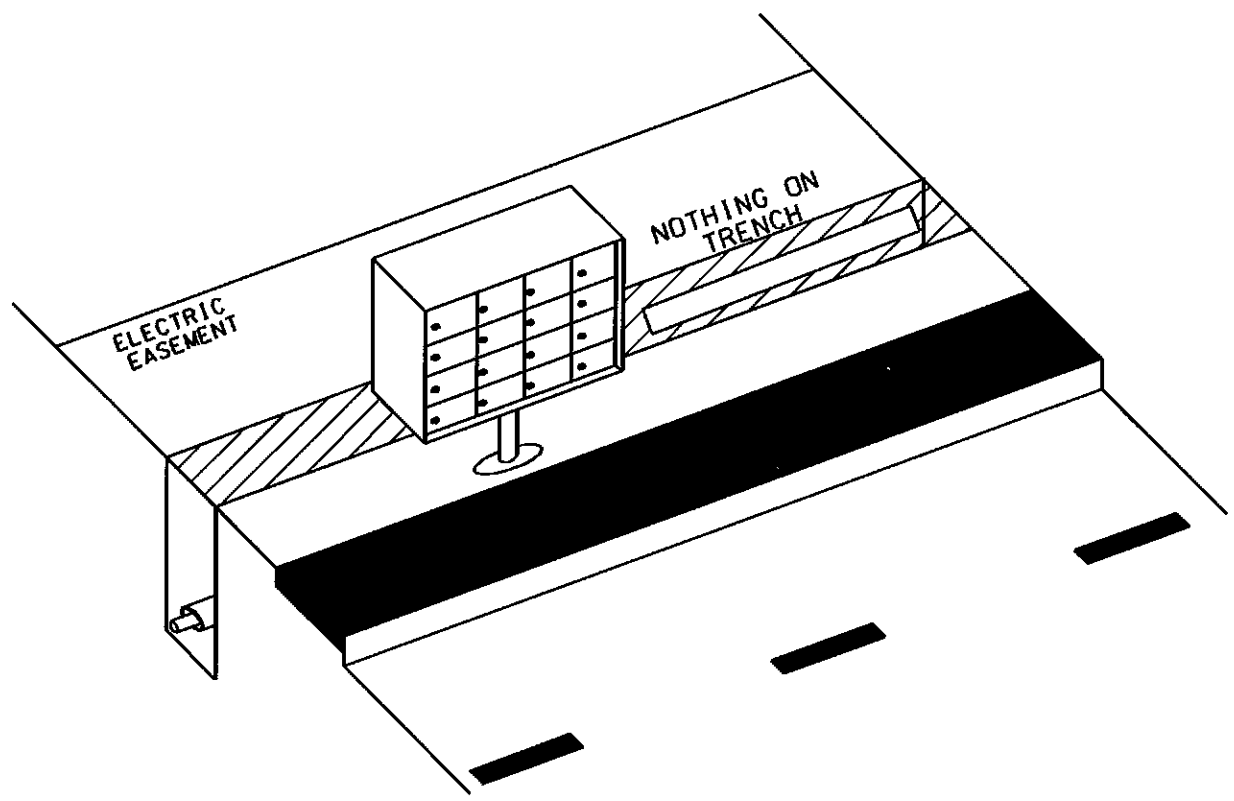

NO



**NOTE:**  
 CLEARANCES FROM EXISTING ELECTRIC UTILITY UNDERGROUND LINES MUST BE 3 FEET WHEN THE EXACT LOCATION HAS BEEN DETERMINED BY POT HOLING THE INFRASTRUCTURE

	<b>CLEARANCES</b>		
	REV.	700-02A	SCALE: NA
POWER & COMMUNICATIONS	DATE: DECEMBER 13, 2003	DRAWN BY: RANTWF	APPROVAL:

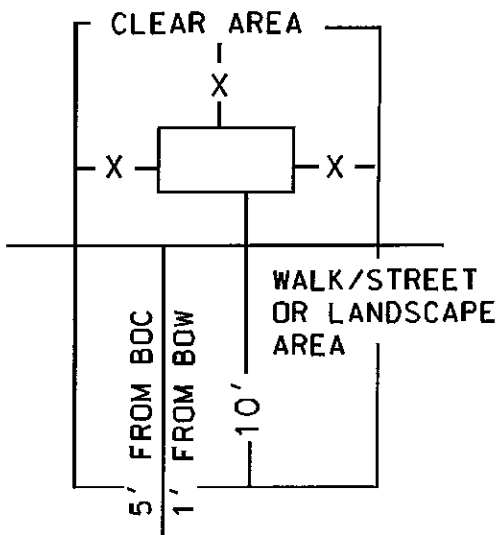
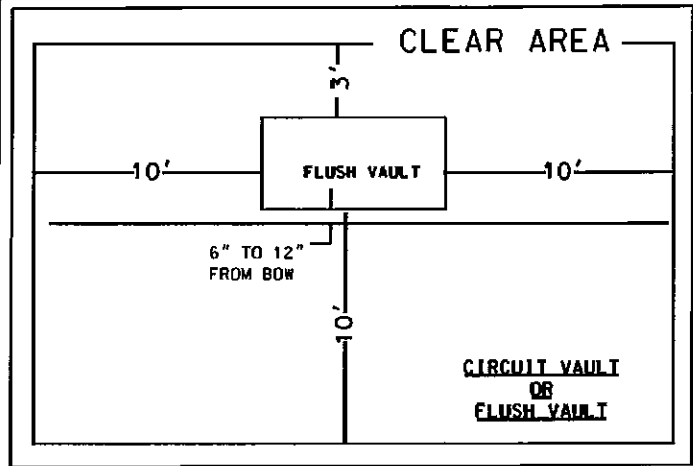
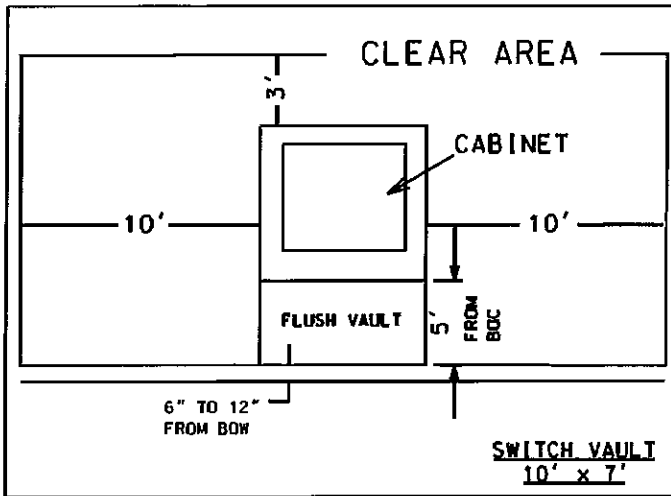

UPRIGHT CABINET

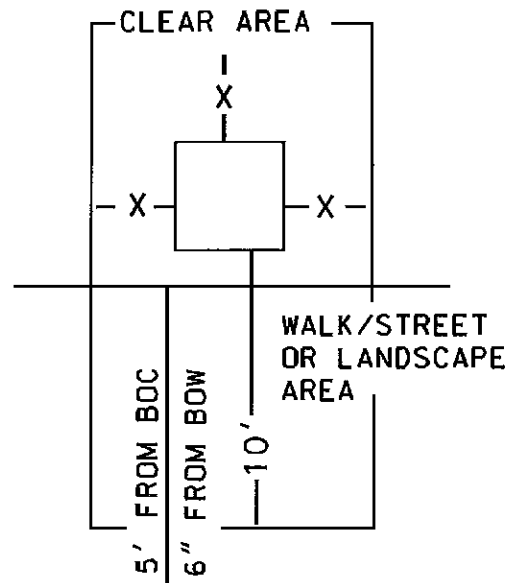

TRANSFORMER

CLEARANCES "X"

- 3' FROM LANDSCAPE MATERIAL
- 3' MINIMUM FROM STRUCTURES
- 3' ADJACENT TO RESIDENTIAL DRIVEWAYS
- 3' MINIMUM FROM A DRIVING SURFACE WITH THE USE OF BOLLARDS
- 5' FROM A DRIVING SURFACE BEHIND A CURB OR PROTECTIVE FEATURE
- 10' FROM A DRIVING SURFACE WHERE NO PROTECTIVE FEATURE IS PROPOSED

1. MAINTAIN MINIMUM CLEARANCES AS NOTED ABOVE
2. BOLLARDS WILL BE INSTALLED AT THE DEVELOPER/OWNER'S EXPENSE WHEN EQUIPMENT IS NOT PROTECTED FROM VEHICULAR TRAFFIC
3. TRANSFORMER LOCATIONS SHALL BE ESTABLISHED BY THE OWNER TO MEET LPC'S MINIMUM CLEARANCES AND ALL FIRE CLEARANCES REQUIRED BY APPLICABLE CODES
4. SOD IN CLEAR AREAS.

	<b>CLEARANCES</b>		
	REV. 1	700-02B	SCALE: NA
POWER & COMMUNICATIONS	DATE: 10/05	DRAWN BY: RANTMF	APPROVAL:

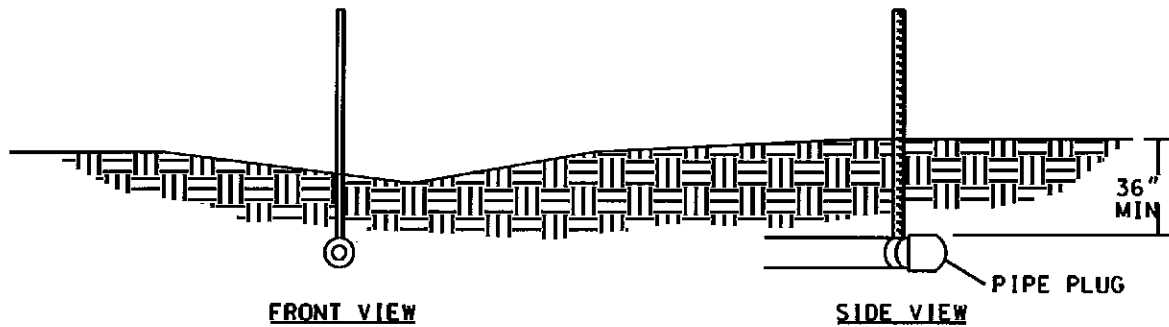
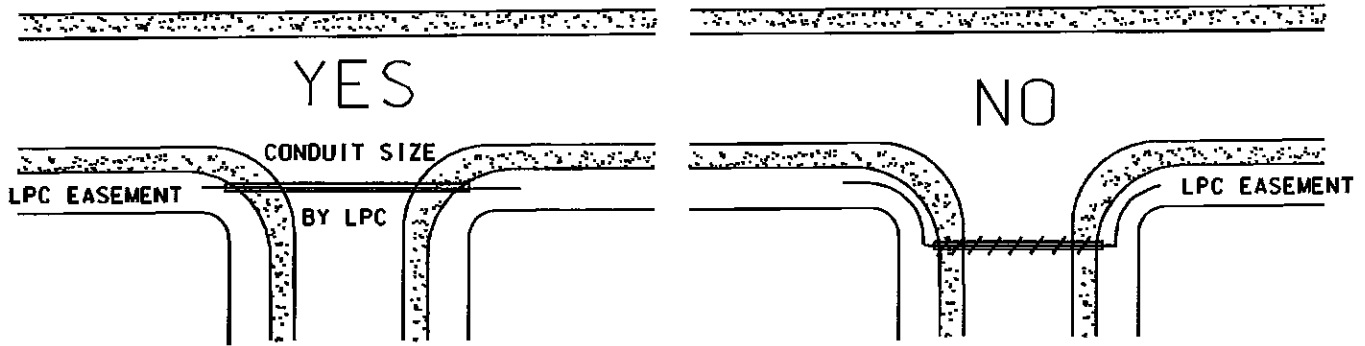

IDENTIFYING TIE MARKER

**NOTES:**

1. DEPTH: MINIMUM 36" - MAXIMUM 48" COMPACTED TO 95%
2. SCHEDULE 40 PVC GLUED AND AIRTIGHT
3. TYPICAL ELECTRIC TRENCH LINE 18" BEHIND THE WALK
4. ALL LPC CROSSINGS SHALL BEGIN AND END IN THE ELECTRIC EASEMENT OR OUTLOT.
5. EXTEND LPC CROSSINGS 3' BEYOND THE CURB OR SIDEWALK.
6. OTHER UTILITY CROSSINGS SHALL BE LOCATED AND MARKED WITH A STAKE. THE STAKE SHALL IDENTIFY THE SIZE AND DEPTH OF THE CROSSING.
7. EXTEND OTHER UTILITY CROSSINGS BEYOND THE ELECTRIC EASEMENT.
8. GAS CROSSINGS SHALL MAINTAIN 5' CLEARANCE FROM ELECTRIC
9. COMMUNICATIONS CROSSINGS MAY SHARE A TRENCH WITH LPC AND MUST BE AT A MINIMUM DEPTH OF 36" IN THE LPC EASEMENT.

	<b>SLEEVE INSTALLATION</b>		
	REV.	700-03	SCALE: NA
POWER & COMMUNICATIONS	DATE: DECEMBER 2003	DRAWN BY: RAN/MF	APPROVAL:

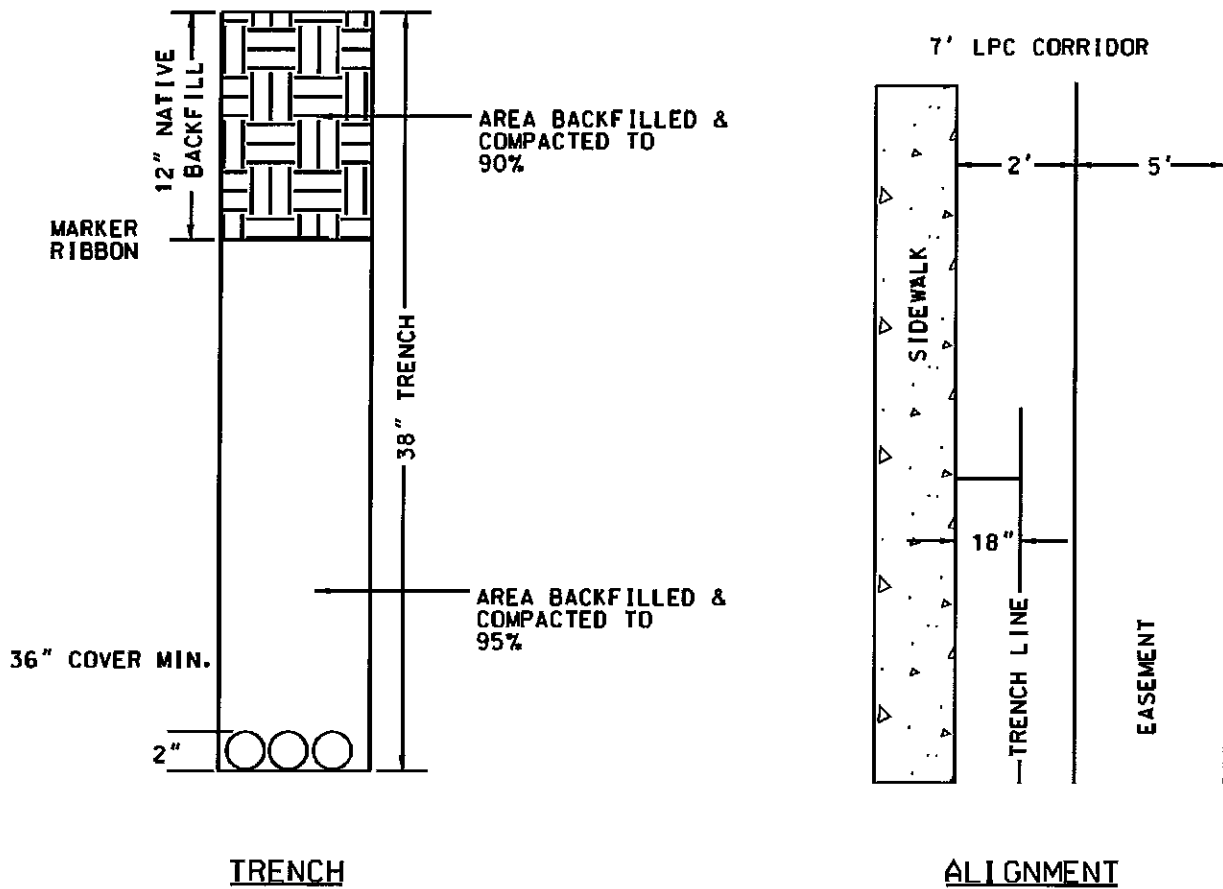

**NOTES:**

1. TRENCH ALIGNMENT IS DETERMINED BY THE RIGHT-OF-WAY AND OR EASEMENTS.
2. MINIMUM TRENCH WIDTH 6" AND MUST PROVIDE A MINIMUM OF 36" OF COVER AND A MAXIMUM OF 48".
3. THE BOTTOM OF THE TRENCH MUST BE SMOOTH AND CONTINUOUS.
4. ALL TRENCH MUST REMAIN OPEN UNTIL INSPECTED BY LPC.
5. MARKER RIBBON TO BE INSTALLED BEFORE FINAL 12".
6. 95% COMPACTION IS REQUIRED TO A POINT 12" BELOW FINAL GRADE AND 90% FOR THE LAST 12".



**TRENCH DETAIL**

REV.

700-04

SCALE: NA

POWER & COMMUNICATIONS

DATE: DECEMBER 2003

DRAWN BY: RANTME

APPROVAL:

**STREET LIGHT**

INSTALLED IN THE TRENCH LINE

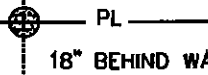

18" BEHIND WALK OR CURB

**STREET LIGHT  
STREET LIGHT SECONDARY GROUND SLEEVE**

STREET LIGHT 6" BEHIND GROUND SLEEVE



STREET LIGHT GROUND SLEEVE 6" BEHIND CURB/WALK  
ELEVATION 4" ABOVE WALK

**SECONDARY GROUND SLEEVE**

GROUND SLEEVE 6" BEHIND WALK



ELEVATION 4" ABOVE WALK

**SECONDARY GROUND SLEEVE  
STREET LIGHT**

STREET LIGHT IN THE TRENCH LINE  
18" BEHIND WALK OR CURB  
6" EITHER SIDE OF GROUND SLEEVE

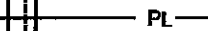

GROUND SLEEVE 6" BEHIND WALK  
ELEVATION 4" ABOVE WALK

**TRANSFORMER GROUND SLEEVE**



SET SLEEVE 6" BEHIND WALK  
ELEVATION 4" ABOVE WALK

**TRANSFORMER GROUND SLEEVE  
SECONDARY GROUND SLEEVE**

TRANSFORMER SLEEVE 6" BEHIND WALK  
ELEVATION 4" ABOVE WALK



SECONDARY GROUND SLEEVE 6"  
BEHIND TRANSFORMER  
ELEVATION 4" ABOVE WALK

**TRANSFORMER GROUND SLEEVE  
STREET LIGHT**

TRANSFORMER SLEEVE 6" BEHIND WALK  
ELEVATION 4" ABOVE WALK



STREET LIGHT IN THE TRENCH LINE  
18" BEHIND WALK OR CURB  
6" EITHER SIDE OF GROUND SLEEVE

**TRANSFORMER GROUND SLEEVE  
SECONDARY GROUND SLEEVE  
STREET LIGHT**

TRANSFORMER SLEEVE 6" BEHIND WALK  
ELEVATION 4" ABOVE WALK



SECONDARY GROUND SLEEVE 6"  
BEHIND TRANSFORMER  
ELEVATION 4" ABOVE WALK  
STREET LIGHT IN THE TRENCH LINE  
18" BEHIND WALK OR CURB  
6" EITHER SIDE OF GROUND SLEEVE

**UPRIGHT PRIMARY JUNCTION  
GROUND SLEEVE  
(1 PHASE & 3 PHASE)**

12 - 18" BEHIND WALK



ELEVATION 4" ABOVE WALK

**FLUSH PRIMARY JUNCTION  
GROUND SLEEVE  
(1 PHASE & 3 PHASE)**

12 - 18" BEHIND WALK

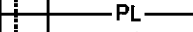

ELEVATION 4" ABOVE WALK



**EQUIPMENT  
ALIGNMENT ON TRENCH**

REV.

700-05

SCALE: NA

POWER & COMMUNICATIONS

DATE: DECEMBER 2003

DRAWN BY: RAWTF

APPROVAL:

PENTA HEAD OR  
LATCH MECHANISM

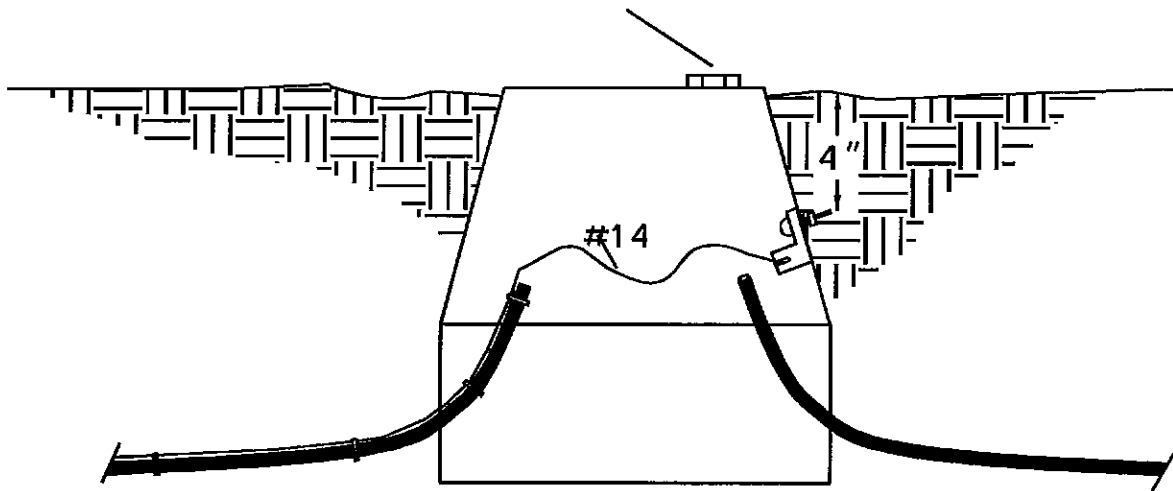

**NOTES:**

**SUBSURFACE INFRASTRUCTURE CREW RESPONSIBILITIES:**

1. TAPE #14 COPPER WIRE TO THE TOP OF THE EMPTY CONDUIT
2. COIL 3 FEET OF WIRE IN METAL AND FIBERGLASS GROUND SLEEVES
3. COIL 10 FEET OF WIRE IN CONCRETE GROUND SLEEVES
4. PROVIDE AS-BUILT DRAWINGS WITH THE LENGTH OF THE CONDUIT AND LOCATION OF THE TRENCH FROM THE BACK OF THE WALK, CURB OR SURFACE FEATURE
5. WHERE THE END OF THE CONDUIT IS BURIED, THE TRACER WIRE SHALL EXTEND TO THE END OF THE CONDUIT.

**LPC CREW RESPONSIBILITY:**

WHERE THE EMPTY CONDUIT RUN ENTERS A PIECE OF EQUIPMENT THE FOLLOWING CONNECTION WILL BE MADE AND IS DEPENDANT UPON THE EQUIPMENT TYPE.

1. METAL ENCLOSURES - THE #14 WILL BE CONNECTED TO THE GROUND BUSS
2. FIBERGLASS ENCLOSURES - A HOLE WILL BE DRILLED 4" BELOW THE PENTA HEAD OR LATCH MECHANISM WHERE A GROUND LUG ASSEMBLY WILL BE INSTALLED
3. CONCRETE VAULT - THE #14 COPPER WIRE TO EXIT THE TOP OF THE VAULT IN THE DIRECTION OF THE EMPTY CONDUIT



**TRACER WIRE INSTALLATION**

REV.

700-06

SCALE: NA

POWER & COMMUNICATIONS

DATE: DECEMBER 2003

DRAWN BY: RANEM

APPROVAL:

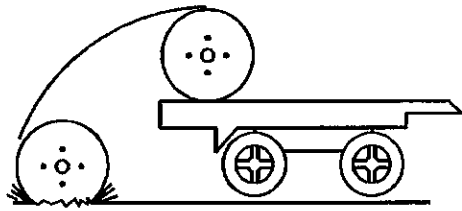

DON'T

When off loading reels from a truck, lower reels carefully using a hydraulic gate, hoist or fork lift truck. Never drop reels. If reels must be rolled, roll in opposite direction of the cable wraps to keep cable from loosening on the reel.

When using a hoist, install a mandrel through the reel arbor holes and attach a sling. Use a spreader bar approximately 6 inches longer than the overall reel width placed between the sling ends just above the reel flanges. This will prevent bending the reel flanges and mashing the cable.

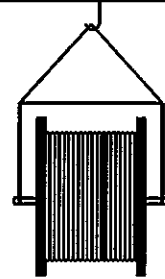

DO

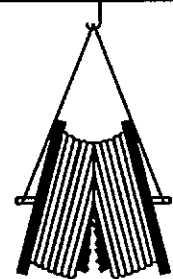

DON'T

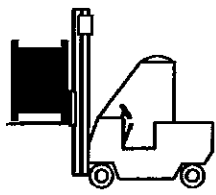

DO

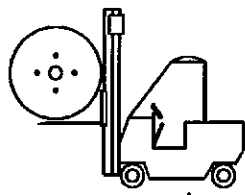

DON'T

If a fork lift is used, approach the reel from the flange side. Position the forks such that the reel is lifted by both reel flanges. Do not allow the lift forks to contact the cable. Care must be taken by the fork lift operator not to make sudden turns or stops.

Cable shipped on wooden or metal reels may be stored outdoors. When selecting a storage site, consideration should be given to:

- \* Traffic patterns during off-loading
- \* Grade and condition of the soil or pavement
- \* Protection from vehicle damage during the time in storage
- \* Environmental conditions such as exposure to heat, corrosive chemicals, etc.

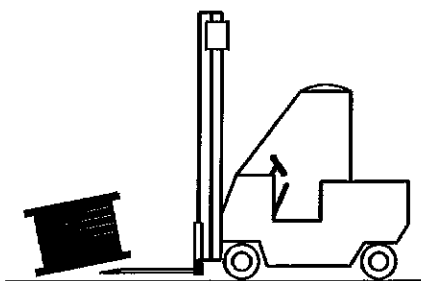

DON'T

Cable reels should be stored on hard surfaces resting on the flanges edge (flanges vertical). Align reels flange to flange and, if possible, arrange so that first in is first out. Multiple reels stacked on top of each other ("Pancake" storage), or storing reels flat (flanges horizontal) is not acceptable. The weight of the stack can total thousands of pounds creating an enormous load on the bottom reel. Also, damage to the reel and/or cable will likely occur when the reel is flipped for transit. A concentration of stress on the reel flange may cause it to break and subsequently damage the cable.



CABLE HANDLING AND STORAGE PROCEDURES

REV.

700-07A

SCALE: NA

POWER & COMMUNICATIONS

DATE: DECEMBER 2003

DRAWN BY: RANTIM

APPROVAL:

For extended storage reels should be stored cradled between railroad ties, power poles or cross arms. Size and spacing of the supports should raise the flange about the ground. This helps keep the flanges from decaying and prevents the reels from rolling.

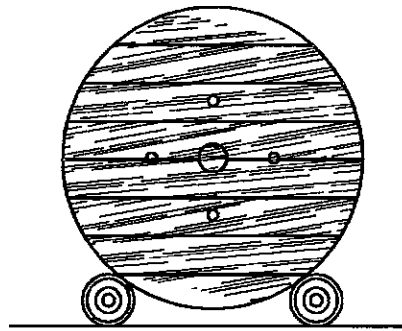

At temporary storage sites where soil may be soft, preservative treated plywood sheets may be used to keep reel flanges from sinking into the ground.

To prevent entrance of water, cable ends should be sealed with plastic end caps. Electrical tape does not offer a sufficient seal. When lengths are cut, cable ends should be immediately resealed and secured.



**CABLE HANDLING AND STORAGE PROCEDURES**

REV.

700-07B

SCALE: NA

POWER & COMMUNICATIONS

DATE: DECEMBER 2003

DRAWN BY: RANTMF

APPROVAL:



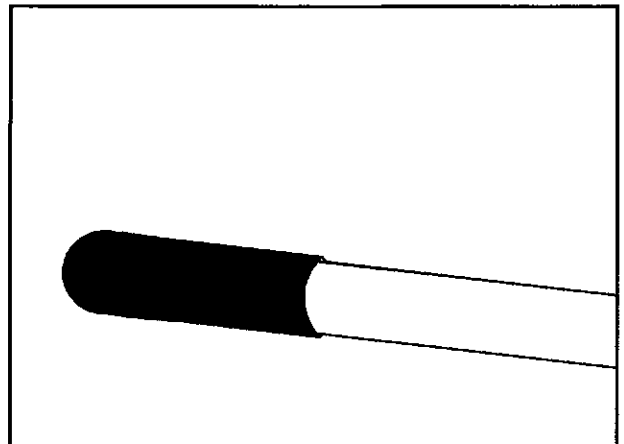
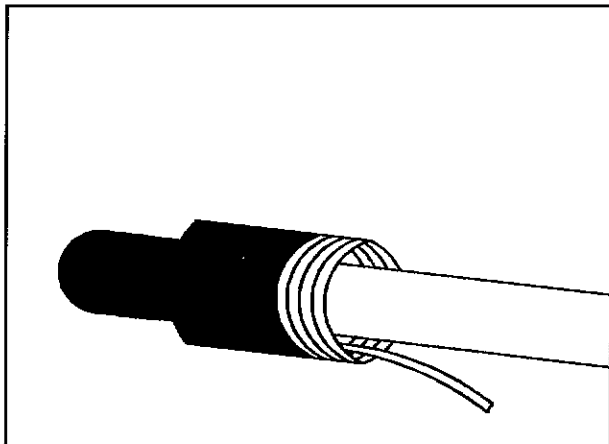
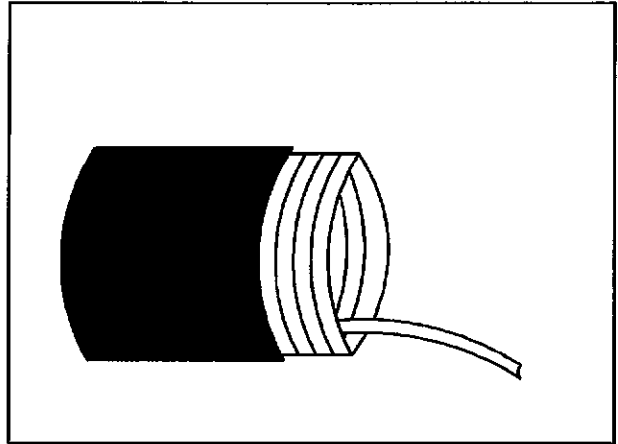
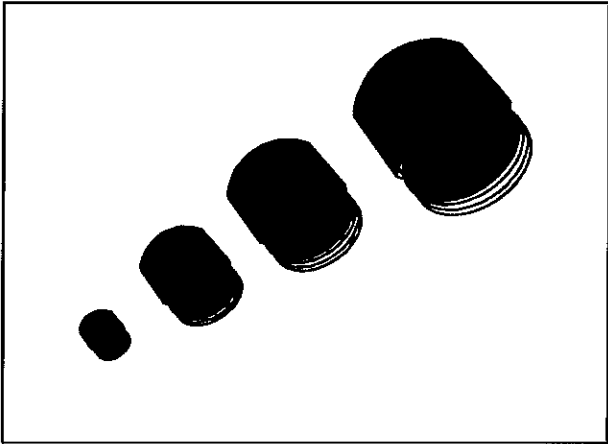

TO PREVENT ENTRANCE OF WATER INTO CABLE, COLD SHRINK SHALL BE INSTALLED ON THE ENDS OF ALL PRIMARY CONDUCTORS



COLD SHRINK INSTALLATION

REV.

700-08

SCALE: NA

POWER & COMMUNICATIONS

DATE: DECEMBER 2003

DRAWN BY: RAWTWF

APPROVAL:



**TOP VIEW**

LEAVE CABLE WITH MINIMAL LOOP FOR TEMPORARY STORAGE

**FRONT VIEW**

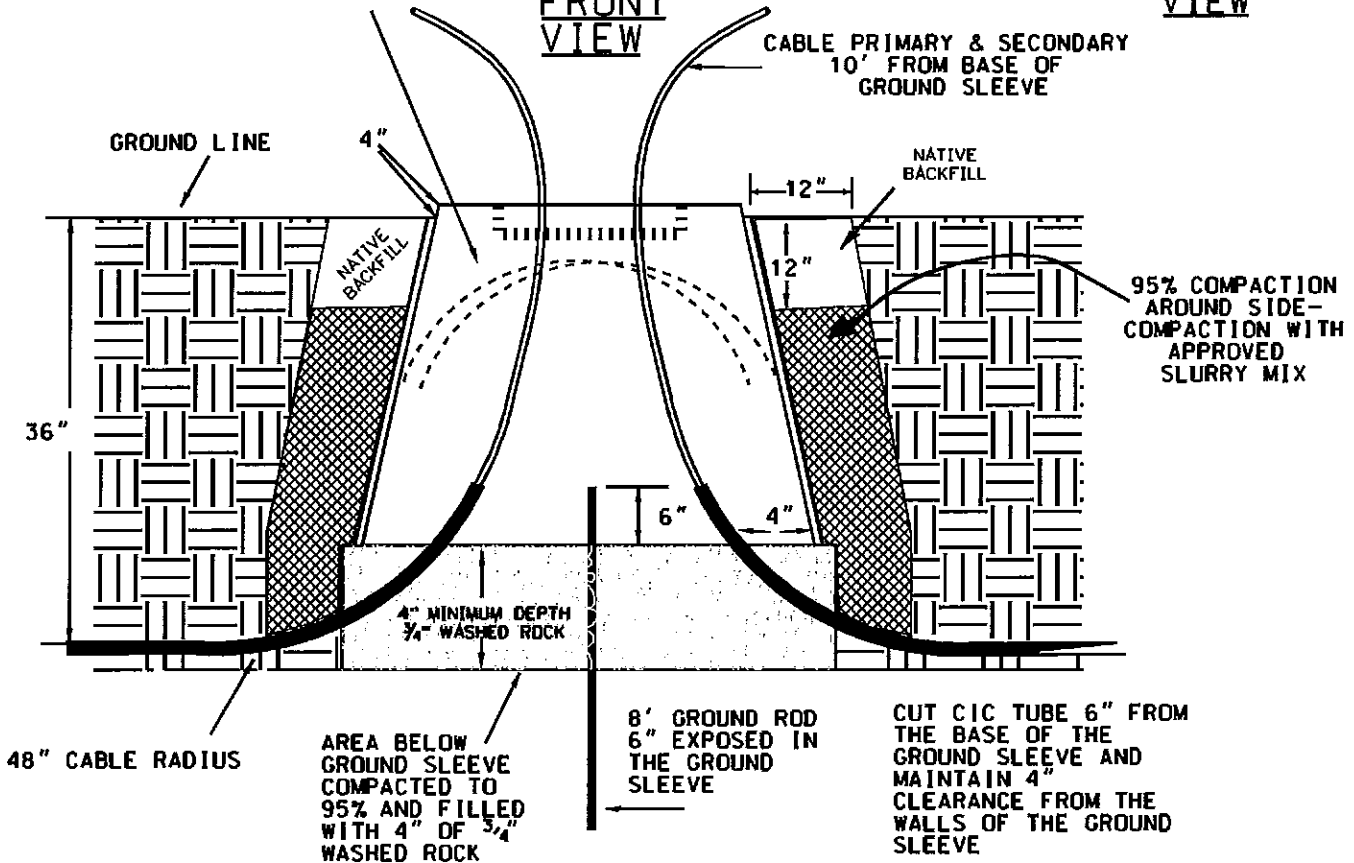

48" CABLE RADIUS

AREA BELOW GROUND SLEEVE COMPACTED TO 95% AND FILLED WITH 4" OF 3/4" WASHED ROCK

8' GROUND ROD 6" EXPOSED IN THE GROUND SLEEVE

CUT C/C TUBE 6" FROM THE BASE OF THE GROUND SLEEVE AND MAINTAIN 4" CLEARANCE FROM THE WALLS OF THE GROUND SLEEVE

95% COMPACTION AROUND SIDE - COMPACTION WITH APPROVED SLURRY MIX

1. GROUND SLEEVE MUST BE LEVEL
2. SET 4" ABOVE FINAL GRADE
3. PROVIDE 95% COMPACTION UNDER AND AROUND THE SLEEVE
4. MINIMUM OF 4" WASHED ROCK TO BE INSTALLED UNDER THE GROUND SLEEVE
5. CABLE LENGTH SHALL BE 15' AND MEASURED FROM THE BASE OF THE GROUND SLEEVE
6. THE CABLE DUCT SHALL HAVE 6" EXPOSED IN THE GROUND SLEEVE
7. CABLE SWEEP INTO GROUND SLEEVE MUST BE GRADUAL AND HAVE A 48" RADIUS
8. AN 8' GROUND ROD SHALL BE PLACED IN THE CENTER OF THE OPENING WITH 6" EXPOSED
9. TRANSFORMER LOCATIONS REQUIRE THE FOLLOWING MINIMUM CLEARANCES
  - a. 3' ON THE SIDES AND BACK FROM LANDSCAPING AND STRUCTURES - CONFIRM LOCAL CODES INCLUDING FIRE FOR GREATER CLEARANCE REQUIREMENTS
  - b. 10' IN THE FRONT WHERE ACCESS DOORS ARE LOCATED
  - c. 5' FROM A DRIVING SURFACE BEHIND A CURB OR PROTECTIVE FEATURE. RESIDENTIAL DRIVEWAY CLEARANCE MAY BE REDUCED TO 3'
  - d. 3' MINIMUM FROM A DRIVING SURFACE WITH THE USE OF BOLLARDS
  - e. 10' FROM A DRIVING SURFACE WHERE NO PROTECTIVE FEATURE IS PROPOSED
  - f. 15' MAXIMUM SETBACK MEASURED FROM THE CENTER FOR LPC TRUCK/LIFTING ACCESS
  - g. REFERENCE CLEARANCE AND BOLLARD DETAIL DRAWINGS
10. CONFIRM THE ORIENTATION OF THE PAD WITH LPC ENGINEERING.

	<b>TRANSFORMER RESIDENTIAL SINGLE PHASE GROUND SLEEVE</b>		
	REV. 3	700-09	SCALE: NA
POWER & COMMUNICATIONS	DATE: 10/07	DRAWN BY: RAWTMF, RZ	APPROVAL:

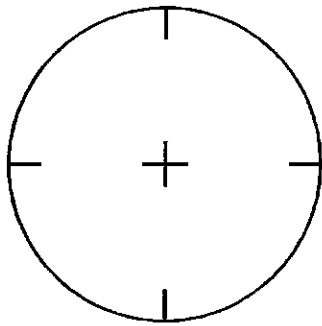

ORIENTATION

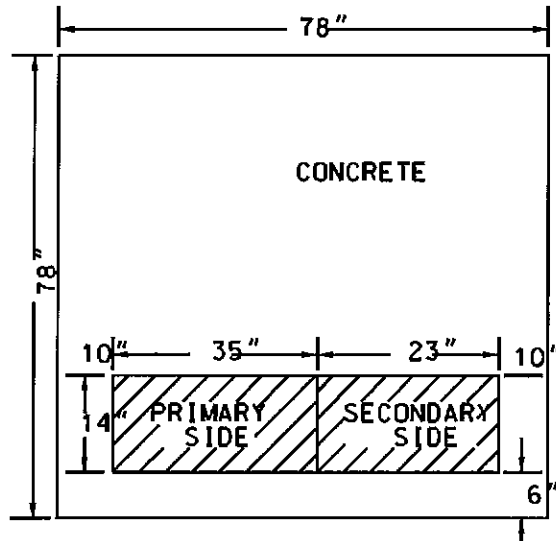

FRONT OF UNIT

THE CUSTOMER SHALL FURNISH A LEVEL CONCRETE PAD IN ACCORDANCE WITH THE SPECIFICATIONS OUTLINED BELOW. THE PAD REMAINS THE PROPERTY OF THE CUSTOMER AND ANY DEFICIENCY IN THE PAD IS THE SOLE RESPONSIBILITY OF THE CUSTOMER TO REPAIR.

1. THE PAD AND ELECTRIC CONDUCTOR BLOCKOUT DIMENSIONS ARE INDICATED ON THE DRAWING.
2. THE PAD SHALL BE A MINIMUM OF 6" THICK, REINFORCED WITH WIRE MESH OR REBAR THROUGHOUT, ABLE TO SUPPORT UP TO 17,000 LBS.
3. THE ELEVATION OF THE TOP OF THE PAD SHALL BE 4" ABOVE THE SURROUNDING FINISHED GRADE.
4. THE PAD SHALL BE INSTALLED LEVEL
5. COMPACTION BENEATH THE PAD MUST BE 95% OF STANDARD PROCTOR, ASTM D698, AT A PLUS OR MINUS 2% OPTIMUM MOISTURE CONTENT. TEST RESULTS SHALL BE PROVIDED TO THE LPC INSPECTOR OR FAXED TO 303-651-8796.
6. TRANSFORMER LOCATIONS SHALL BE ESTABLISHED BY THE OWNER
7. MINIMUM CLEARANCE REQUIREMENTS
  - a. 3' ON THE SIDES AND BACK OF THE PAD FROM SURROUNDING STRUCTURES; CONFIRM LOCAL CODES INCLUDING FIRE FOR GREATER REQUIREMENTS
  - b. 3' ON THE SIDES AND BACK FROM LANDSCAPING, FENCES, ETC.
  - c. 10' IN THE FRONT WHERE ACCESS DOORS ARE LOCATED
  - d. 3' MINIMUM FROM A DRIVING SURFACE WITH THE USE OF BOLLARDS
  - e. 5' FROM A DRIVING SURFACE BEHIND A CURB OR PROTECTIVE FEATURE
  - f. 10' FROM A DRIVING SURFACE WHERE NO PROTECTIVE FEATURE IS PROPOSED
  - g. MAXIMUM 15' MEASURED FROM THE CENTER OF THE UNIT TO A TRUCK RATED DRIVING SURFACE FOR LPC TRUCK/LIFTING ACCESS
  - h. REFERENCE CLEARANCE AND BOLLARD DETAIL DRAWINGS
8. THE NUMBER AND SIZE OF THE SECONDARY VOLTAGE CONDUITS ARE TO BE DETERMINED AND INSTALLED BY THE CUSTOMER'S ELECTRICIAN. WHEN THE NUMBER OF CONDUITS EXCEED 6 SECONDARY RUNS, APPROVAL BY LPC IS REQUIRED
9. THE PAD SHALL BE ORIENTATED PER LPC



**TRANSFORMER  
COMMERCIAL THREE PHASE  
CONCRETE PAD**

REV. B

700-10

SCALE: NA

POWER & COMMUNICATIONS

DATE: 4/07

DRAWN BY: RANIMF

APPROVAL:

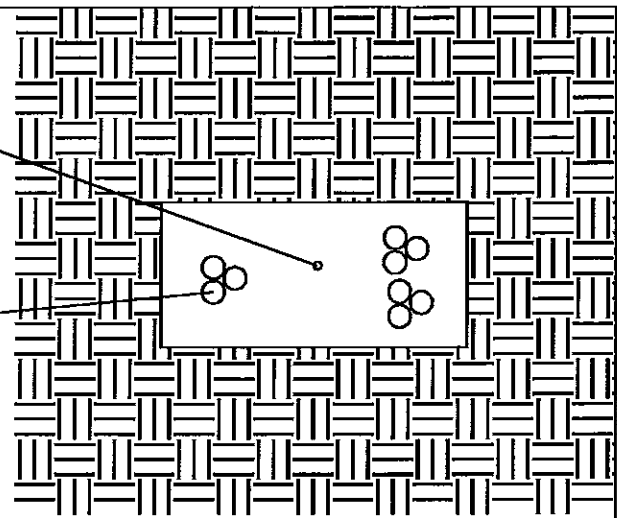

TOP VIEW

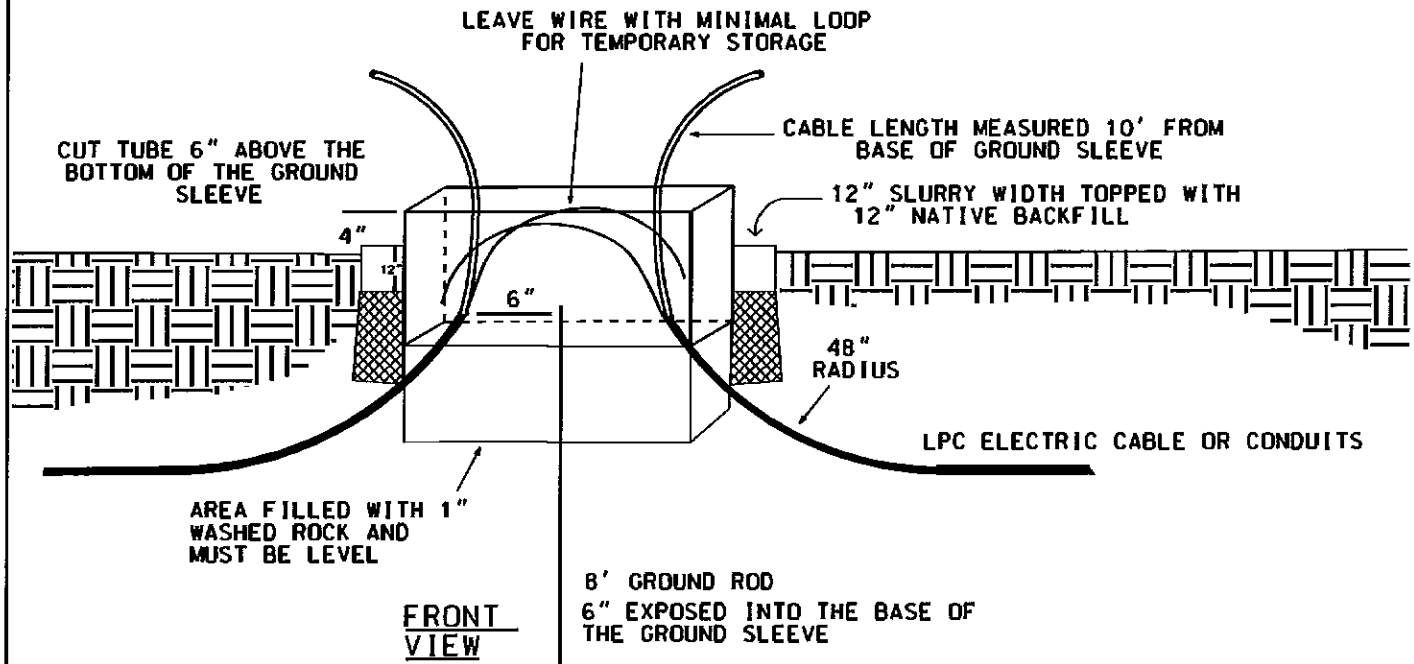

FRONT VIEW

1. GROUND SLEEVE MUST BE LEVEL
2. SET 4" ABOVE FINAL GRADE
3. PROVIDE 95% COMPACTION UNDER THE SLEEVE
4. PROVIDE SIDE COMPACTION AROUND SLEEVE WITH 12" APPROVED SLURRY MIX
5. MINIMUM OF 6" WASHED ROCK TO BE INSTALLED UNDER THE GROUND SLEEVE
6. CABLE LENGTH SHALL BE 10' AND MEASURED FROM THE BASE OF THE GROUND SLEEVE
7. THE CABLE DUCT SHALL HAVE 6" EXPOSED IN THE GROUND SLEEVE
8. CABLE SWEEP INTO GROUND SLEEVE MUST BE GRADUAL AND HAVE A 48" RADIUS
9. AN 8' GROUND ROD SHALL BE PLACED IN THE CENTER OF THE OPENING WITH 6" EXPOSED
10. GROUND SLEEVES REQUIRE THE FOLLOWING CLEARANCES
  - a. 10' FROM THE FRONT OF THE UNIT FOR ACCESS
  - b. 3' ON THE SIDES AND BACK FROM STRUCTURES OR LANDSCAPE MATERIAL
  - c. 3' MINIMUM FROM A DRIVING SURFACE WITH THE USE OF BOLLARDS
  - d. 5' FROM A DRIVING SURFACE BEHIND A CURB OR PROTECTIVE FEATURE. RESIDENTIAL DRIVEWAY CLEARANCE MAY BE REDUCED TO 3'
  - e. 10' FROM A DRIVING SURFACE WHERE NO CURB OR PROTECTIVE FEATURE IS PROPOSED
  - f. REFERENCE CLEARANCE AND BOLLARD DETAIL DRAWINGS

	PRIMARY JUNCTION FACILITY GROUND SLEEVE		
	REV. 2	700-11	SCALE: NA
POWER & COMMUNICATIONS	DATE: 10/05.12/07	DRAWN BY: RAWTMF KZ	APPROVAL:

SECONDARY OR LOW VOLTAGE CABLE

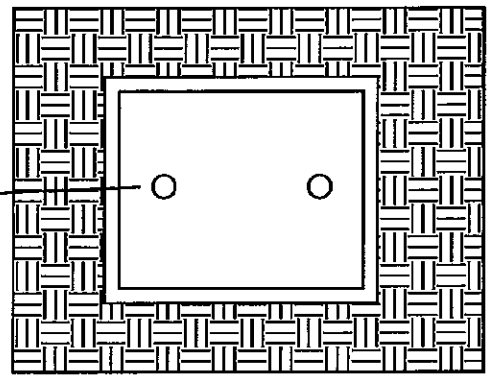

TOP  
VIEW

LEAVE WIRE WITH MINIMAL LOOP  
FOR TEMPORARY STORAGE

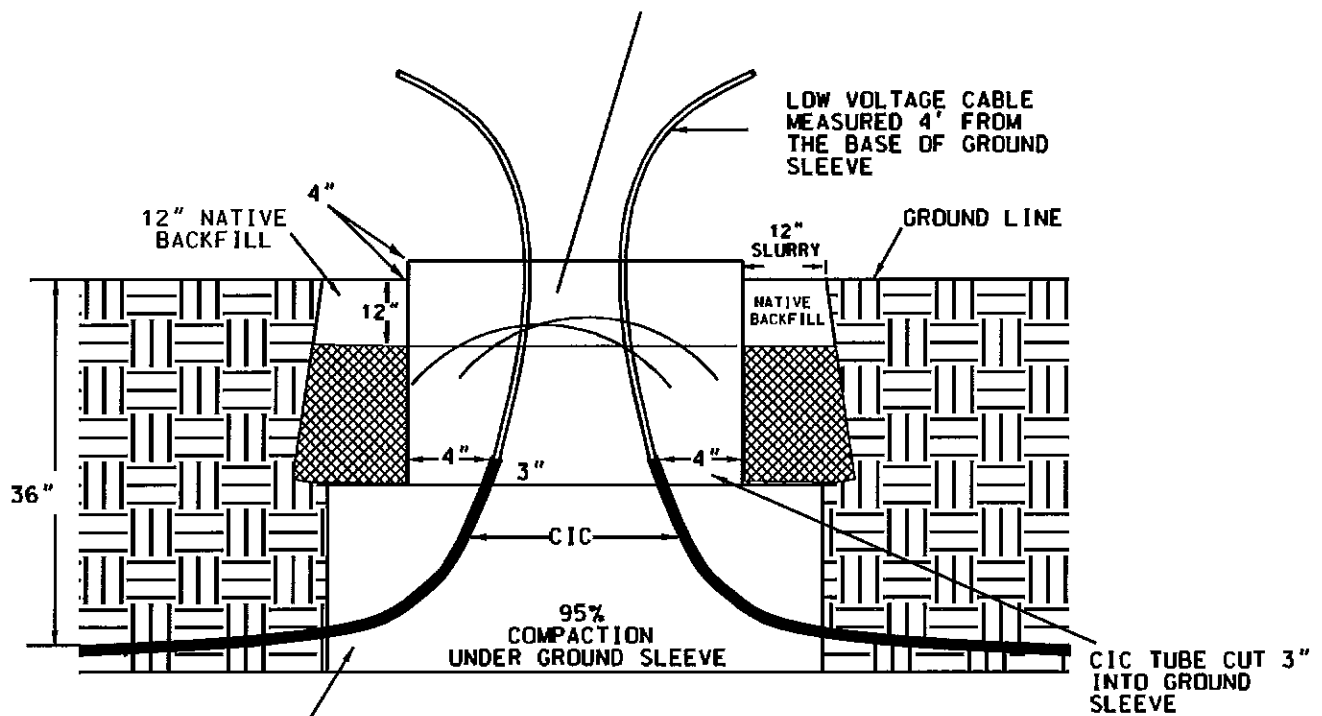

48" RADIUS

FRONT  
VIEW

1. GROUND SLEEVE MUST BE LEVEL
2. SET 4" ABOVE FINAL GRADE
3. PROVIDE 95% COMPACTION UNDER AND AROUND THE SLEEVE
4. PROVIDE SIDE COMPACTION WITH 12" APPROVED SLURRY MIX
5. CABLE LENGTH SHALL BE 4' AND MEASURED FROM THE BASE OF THE GROUND SLEEVE
6. THE CABLE DUCT SHALL HAVE 3" EXPOSED IN THE GROUND SLEEVE
7. CABLE SWEEP INTO GROUND SLEEVE MUST BE GRADUAL AND HAVE A 48" RADIUS
8. MUST MAINTAIN CLEARANCES FROM VEHICLES OR BE TRAFFIC RATED; REFERENCE CLEARANCE AND BOLLARD DETAIL DRAWINGS

	SECONDARY JUNCTION FACILITY GROUND SLEEVE		
	REV. 2	700-12	SCALE: NA
POWER & COMMUNICATIONS	DATE: 10/D7	DRAWN BY: RANTMF, KZ	APPROVAL:

11' TO  
35'

8' TO  
30'

18" TAIL OUT OF STREET LIGHT OR  
CONCRETE BASE

NOTES:

1. SET POLE STRAIGHT
2. 95% COMPACTION IS REQUIRED AROUND THE POLE
3. 20' FIBERGLASS POLES SHALL HAVE 12/2 IN DUCT INSTALLED TO THE TOP OF THE POLE
4. 30' - 35' FIBERGLASS POLES SHALL HAVE #12 ROMEX FROM THE SECONDARY GROUND SLEEVE
5. KEEP THE INSIDE OF THE POLE FREE OF BACKFILL MATERIAL BY TAPING THE OPENINGS CLOSED

18"

24"

12/2 IN TUBE



STREET LIGHT POLE

REV.

700-13

SCALE: NA

POWER & COMMUNICATIONS

DATE: DECEMBER 2003

DRAWN BY: RARTMF

APPROVAL:

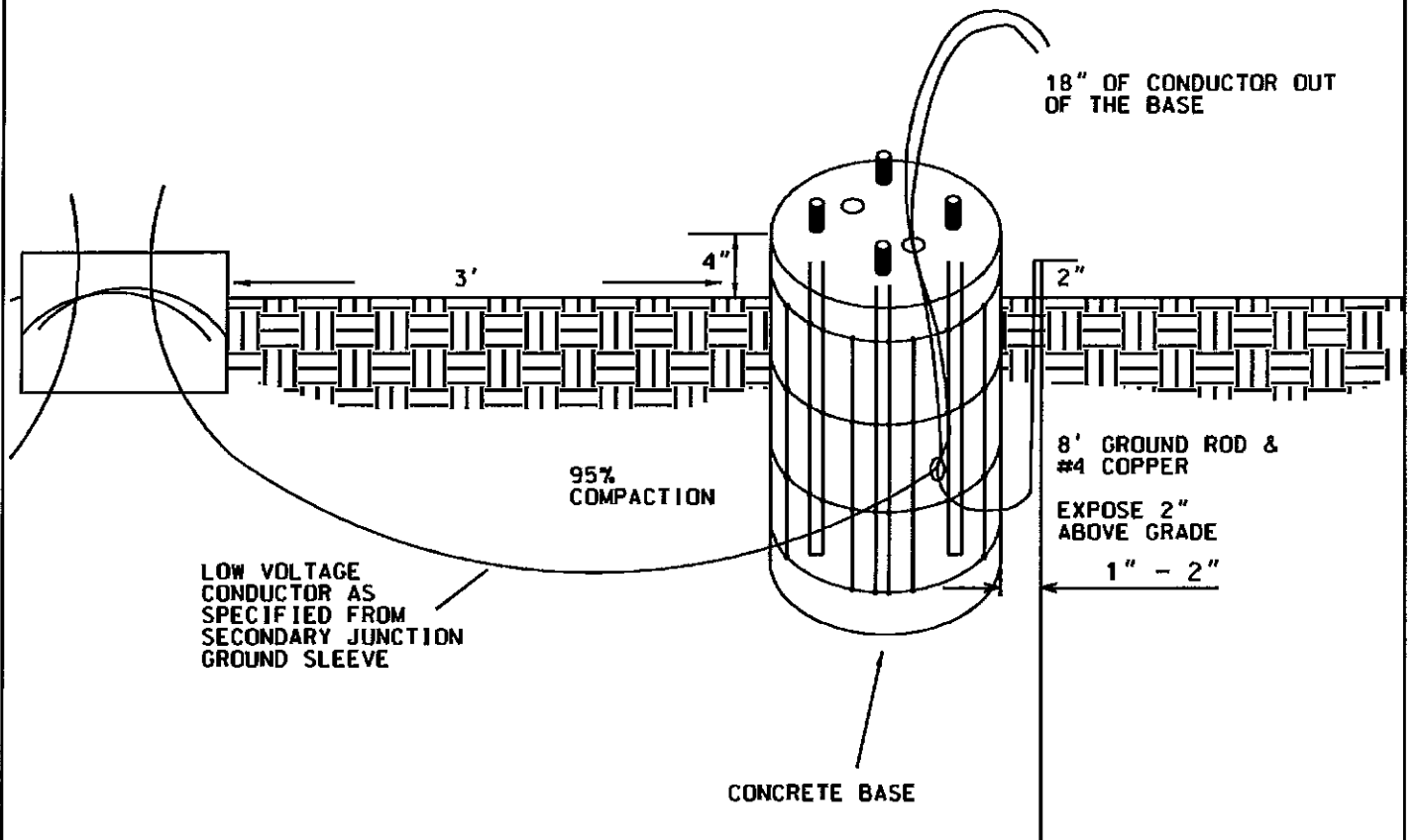

1. CONCRETE BASE MUST BE LEVEL
2. SET 4" ABOVE FINAL GRADE
3. INSTALL AN 8' GROUND ROD & #4 COPPER
4. PROVIDE 95% COMPACTION UNDER AND AROUND THE CONCRETE BASE

	<b>STREET LIGHT BASE</b>		
	REV. 2 1/10/05	<b>700-14</b>	SCALE: NA
POWER & COMMUNICATIONS	DATE: DECEMBER 2003	DRAWN BY: RAWTM	APPROVAL:

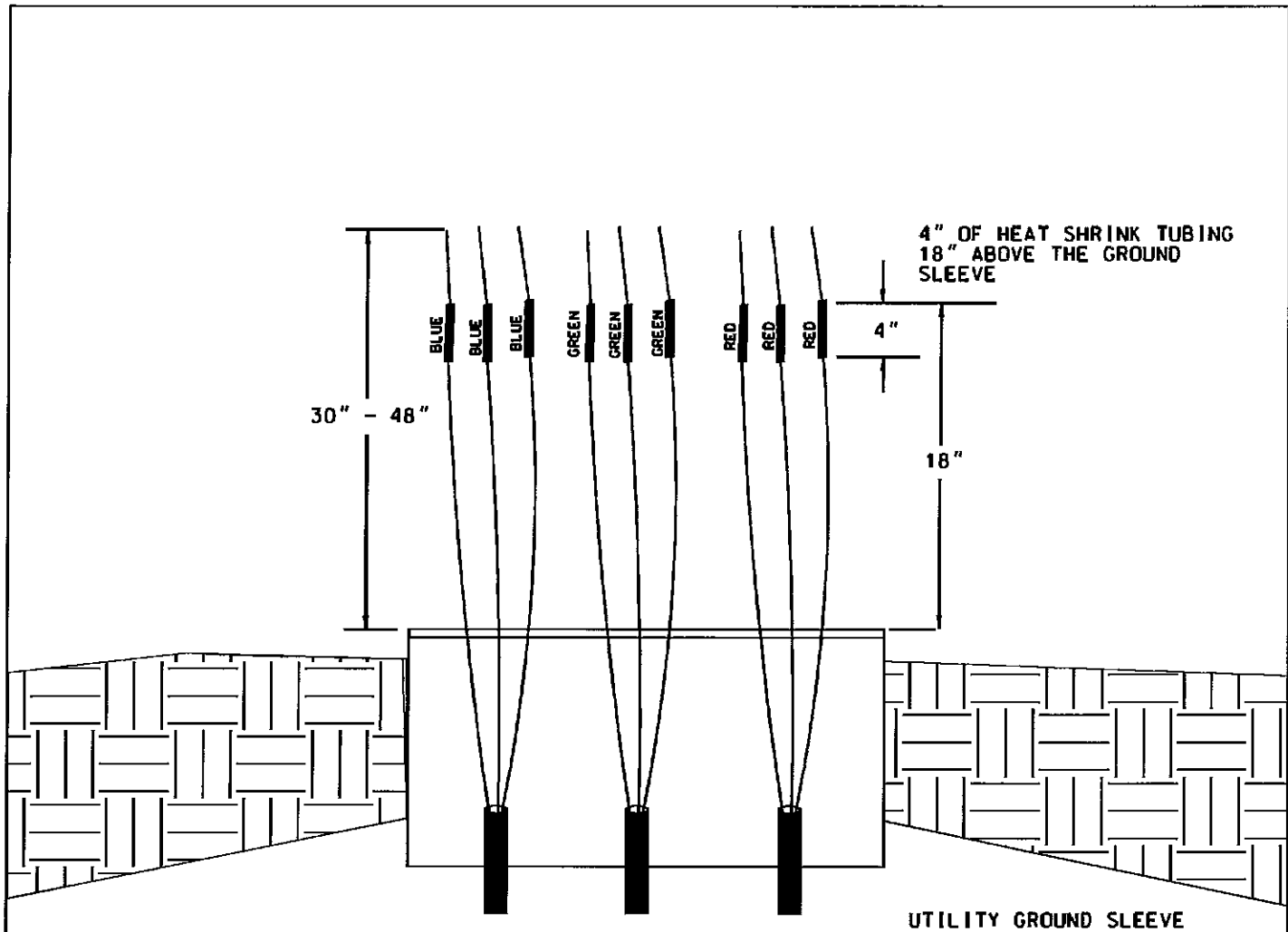

UTILITY GROUND SLEEVE

**APPLICATION:**

LOCATIONS WHERE MORE THAN TWO RESIDENTIAL SERVICE LATERALS TAKE OFF FROM A SECONDARY JUNCTION FACILITY OR FOR MULTI FAMILY OUT OF A TRANSFORMER.

1. SERVICE LATERAL CONDUCTORS SHALL BE CUT A LENGTH THAT ALLOWS THEM TO EXTEND 30" ABOVE THE JUNCTION BOX LID OR 49" ABOVE THE TRANSFORMER GROUND SLEEVE
2. ALL CONDUCTORS OF EACH SERVICE LATERAL SHALL BE MARKED USING HEAT SHRINK TUBING WITH A COLOR THAT IS UNIQUE TO THE UNIT IT SERVES
3. THE COLOR IDENTIFIER SHALL BE AT LEAST 4" LONG AND SHALL BE PLACED 18" ABOVE THE JUNCTION BOX LID OR GROUND SLEEVE.
4. CONDUCTORS SHALL ALSO BE MARKED IN THE METER HOUSING USING COLORED HEAT SHRINK THAT IS AT LEAST 1 INCH LONG
5. THE COMPACTION UNDER AND AROUND THE GROUND SLEEVE MUST BE RESTORED TO 95% AFTER THE INSTALLATION OF THE SERVICE LATERAL

	<b>SERVICE LINE IDENTIFICATION</b>		
	REV.	700-15	SCALE: NA
POWER & COMMUNICATIONS	DATE: DECEMBER 2003	DRAWN BY: HANTMF	APPROVAL:



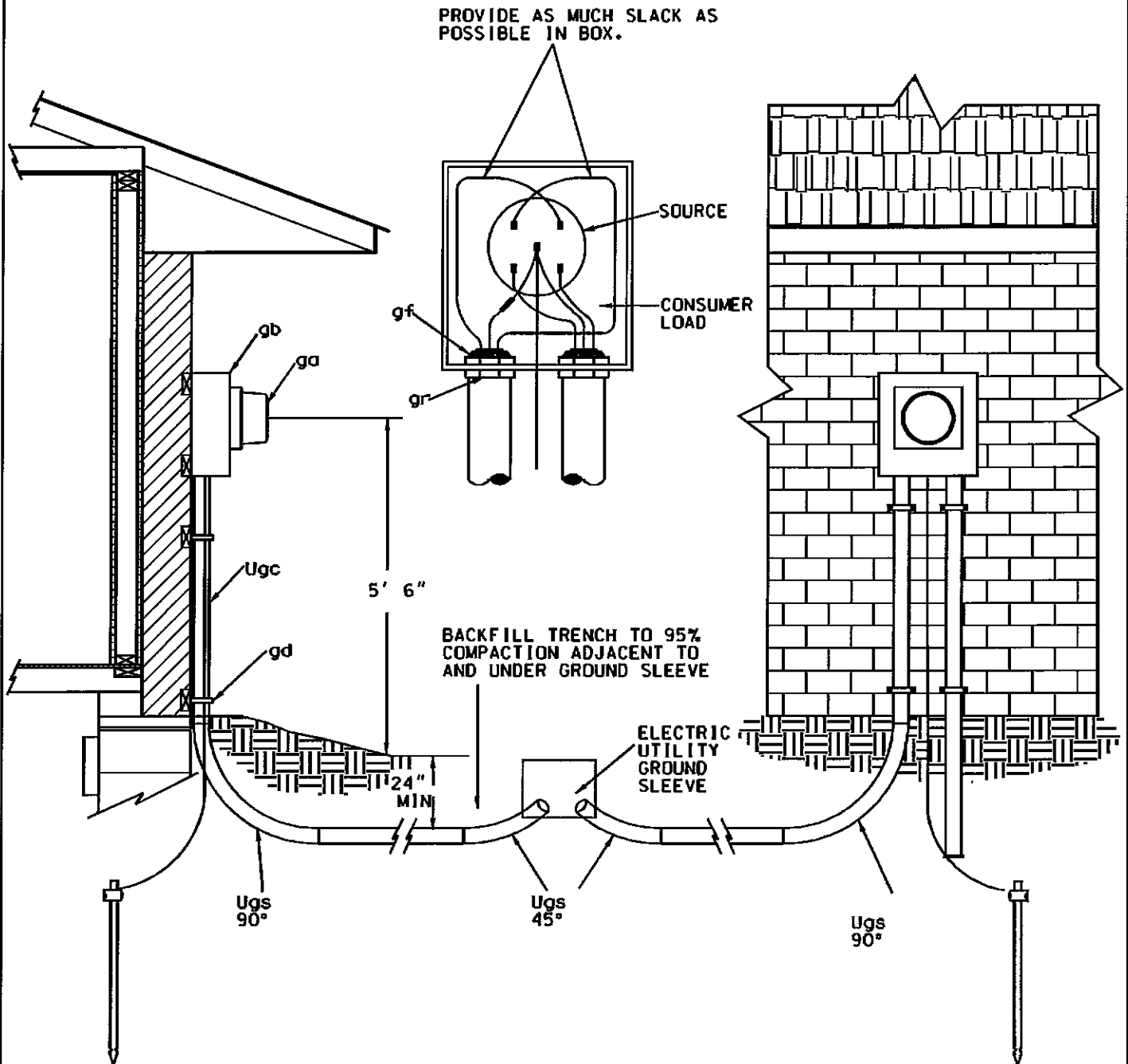

**NOTES:**

1. METER SHALL BE IN DIRECT LINE OF SIGHT WITH THE UTILITY LOW VOLTAGE GROUND SLEEVE OR JUNCTION BOX. APPLIES TO 200 AMPS OR LESS
2. METER SHALL BE LOCATED IN THE FRONT 1/4 OF THE HOUSE OR WILL BE CHANGED TO A REMOTE READ TECHNOLOGY AT THE BUILDER OR HOMEOWNER'S EXPENSE
3. 200 AMP SERVICES SHALL HAVE A LEVER BYPASS METER BASE
4. SERVICES LARGER THAN 200 AMPS ARE OWNED AND MAINTAINED BY THE CUSTOMER
5. CONDUIT TO BE 2" SCHEDULE 40 PVC EXCEPT AS NOTED
6. ALL CONDUIT SWEEPS SHALL BE 24" RADIUS. SWEEP AND RISER AT BUILDING SHALL BE SCH. 80 PVC
7. METER HOUSING AND PIPE STRAPS ARE TO BE ATTACHED TO HOUSE FRAMING WITH 1/4" LAG BOLTS.
8. 48" OF SECONDARY CONDUCTOR, OR 30" ABOVE THE JUNCTION BOX LID SHALL BE COILED IN THE JUNCTION BOX FOR LPC TERMINATIONS
9. CALL 1-800-922-1987 TO OBTAIN UTILITY LOCATES

ITEM	QTY	MATERIAL
ga	1	Meter, as required
gb	1	Meter socket
gd	2	2-hole pipe strap with 1/4" lag bolts.
gr	2	Conduit locknuts, size as required
Ugs	1	Conduit sweep, 24" Radius, sch. 80
Ugc	1	Conduit, sch. 80, dia. & length as req'd



**METERING SINGLE FAMILY**

REV. 9

700-16

SCALE: NA

POWER & COMMUNICATIONS

DATE: 8/05

DRAWN BY: RANTMF

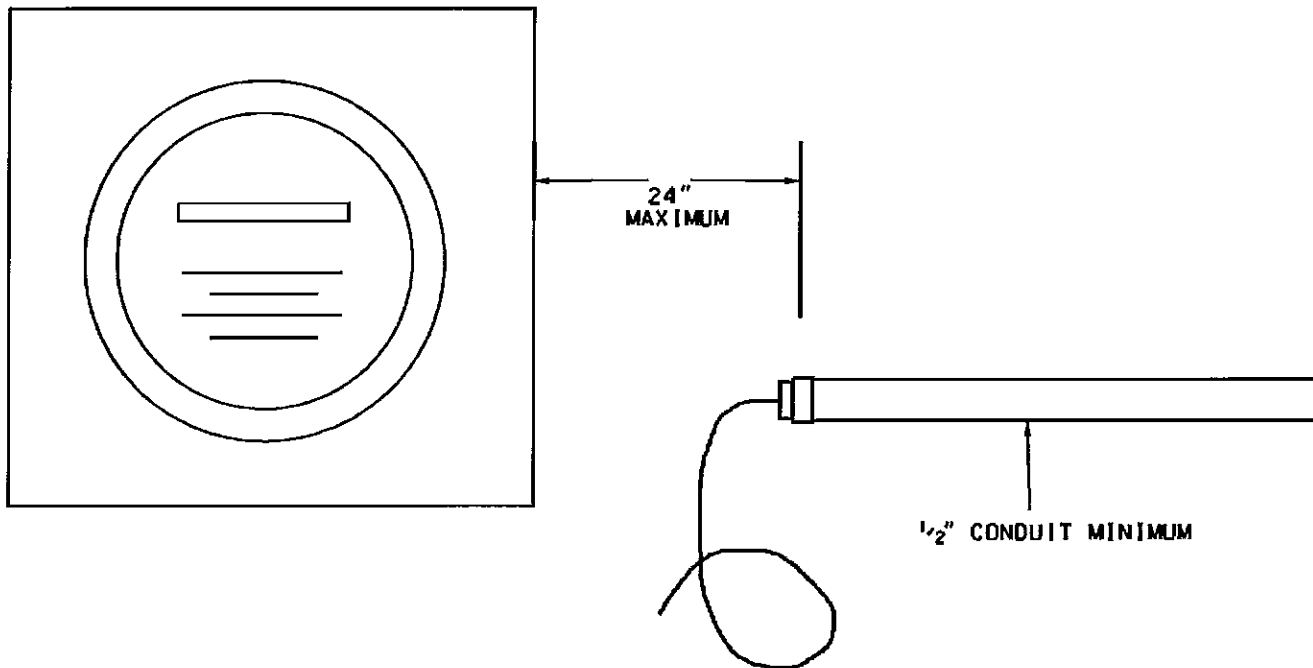

**LOAD SURVEY METERING / PHONE LINE SPECIFICATION**

1. PHONE LINES ARE REQUIRED FOR ELECTRIC SERVICES 1000 AMPS 277/480 OR 2000 AMPS 120/208 AND GREATER
2. PHONE LINE SHALL BE A DEDICATED LINE, SINGLE PAIR, ANALOG TYPE
3. PHONE LINE SHALL BE INSTALLED IN 1/2" CONDUIT MOUNTED WITHIN 24" OF THE METER HOUSING AND IN ACCORDANCE TO THE NATIONAL ELECTRIC CODE.
4. PHONE LINES SHALL BE INSTALLED IN THE CONDUIT WITH A 36" PIGTAIL LEFT FOR FINAL CONNECTION INTO THE METER HOUSING
5. LPC WILL INSTALL A WEATHER PROOF FLEXIBLE CONDUIT FROM THE END OF THE CONDUIT TO THE METER HOUSING AND CONNECT THE PHONE LINE TO THE METER MODEM.
6. THIS SPECIFICATION HAS BEEN APPROVED BY THE CITY OF LONGMONT'S ELECTRICAL INSPECTOR AND NO ADDITIONAL CITY INSPECTION OF THE PHONE LINE IS REQUIRED.
7. LPC METERING DIVISION WILL CONFIRM THE SPECIFICATION HAS BEEN FOLLOWED. IF NOT INSTALLED, LPC AT ITS DISCRETION MAY DISCONNECT THE SERVICE.

	<b>METERING PHONE LINE</b>		
	REV. 2	700-17	SCALE: NA
POWER & COMMUNICATIONS	DATE: 11/14/05	DRAWN BY: RANTMF	APPROVAL:

## BOLLARD PROTECTION MEASURES

ELECTRICAL EQUIPMENT REQUIRES CLEARANCE OR SETBACK ON ALL SIDES FROM VEHICULAR TRAFFIC. THIS INCLUDES DRIVEWAYS, ALLEYS, PARKING LOTS, ETC. PROTECTION SUCH AS BOLLARDS WILL BE INSTALLED AT THE DEVELOPER/OWNER'S EXPENSE.

### BOLLARD POSITIONS AND CRITERIA

- 10' CLEAR ZONE IN FRONT OF ALL EQUIPMENT DOORS
- 6" MINIMUM DISTANCE FROM THE CONCRETE PAD
- 3' MINIMUM DEPTH

#### RESIDENTIAL

- 4" MINIMUM DIAMETER
- 3' MINIMUM HEIGHT

#### COMMERCIAL

- 6" MINIMUM DIAMETER
- 4' MINIMUM HEIGHT

QUANTITY AND LOCATION OF BOLLARDS REQUIRED IS SUBJECT TO SITE CONDITIONS AND SHOULD BE DISCUSSED WITH LPC ENGINEERING.

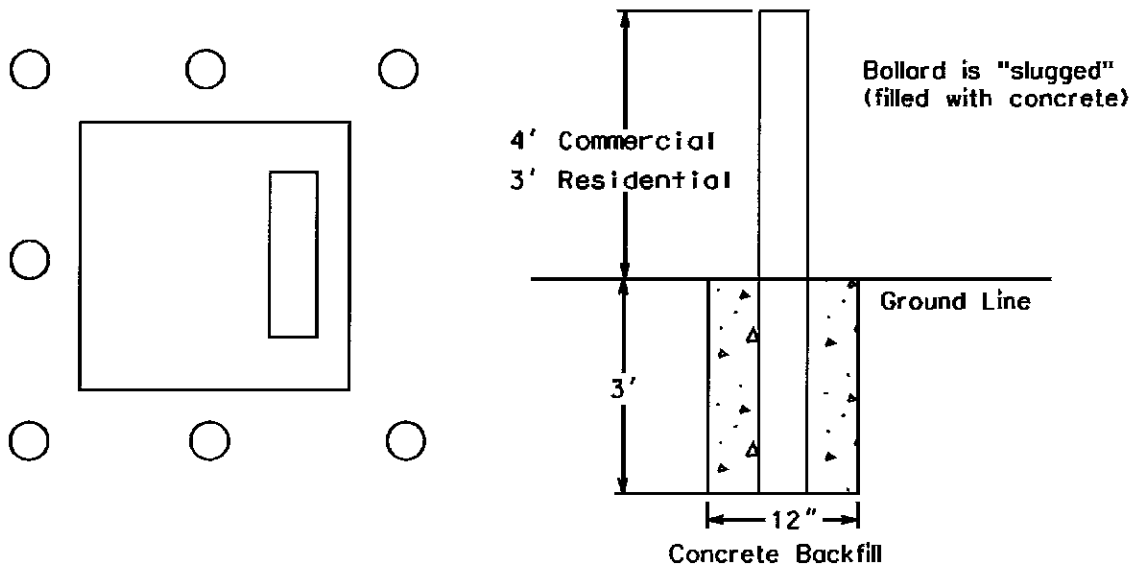

	<b>BOLLARD INSTALLATION</b>		
	REV. 3	700-18	SCALE: NA
	POWER & COMMUNICATIONS	DATE: 10/05	DRAWN BY: PJ/JH